

ENGINEERING DATA
SIL-BRAZE INFORMATION

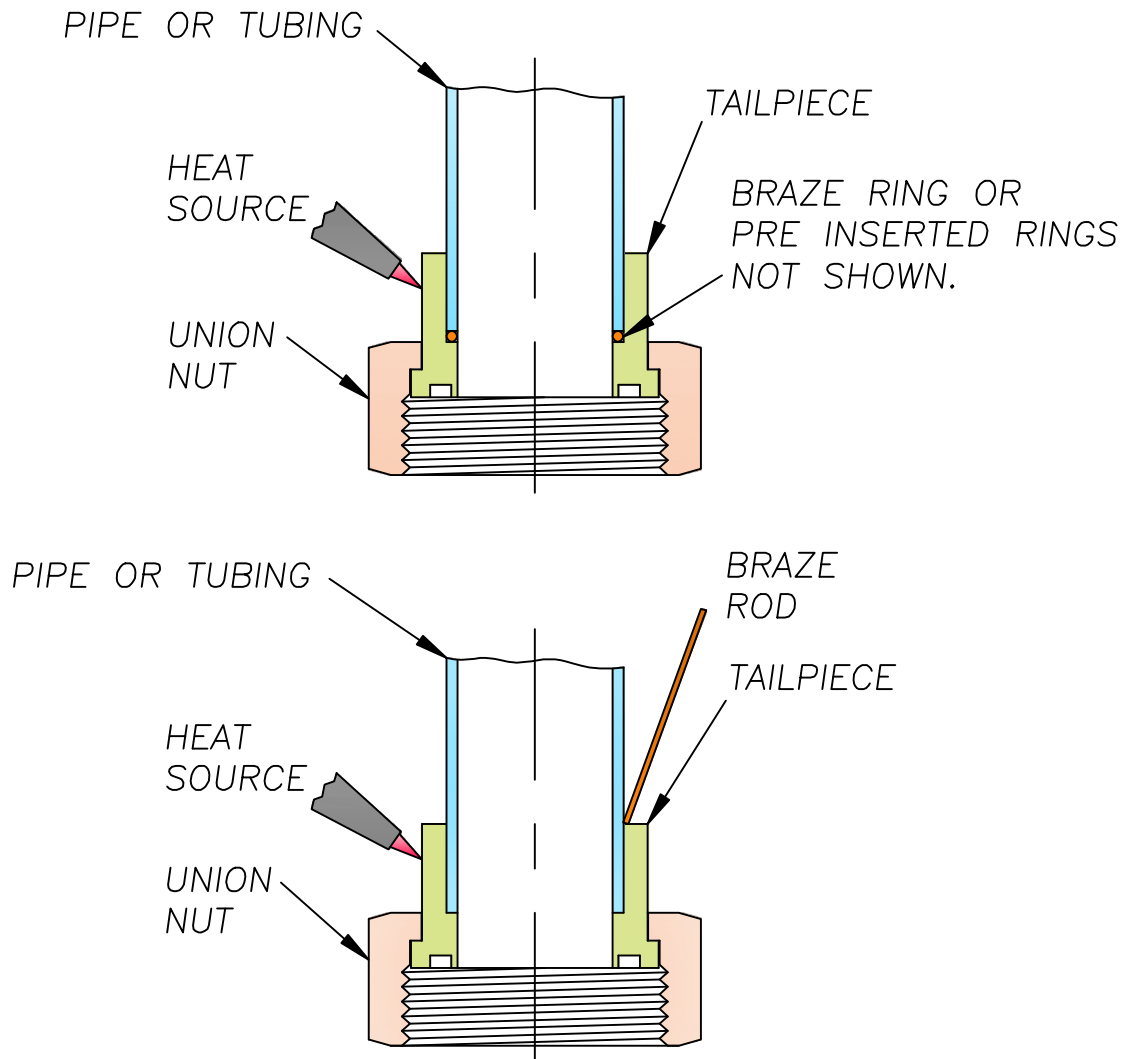

BRAZING IS A RELIABLE, ECONOMICAL HEAT SEALED JOINT.
ALL METHODS OF BRAZING; TORCH, INDUCTION HEATING,
FURNACE, PREINSERTED RING OR FACE FED CAN BE USED.

DERBYSHIRE MARINE PRODUCTS LLC, HARLEYSVILLE, PA 19438

TEL: 267-222-8900, FAX: 267-222-8865

Web: www.derbyshiremp.com

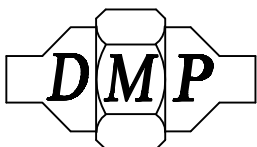

"GET THE CONNECTION"