

ENGINEERING DATA HOW TO INSTALL "U" CUP STEM SEALS IN DMP "FFS SYSTEM" VALVES

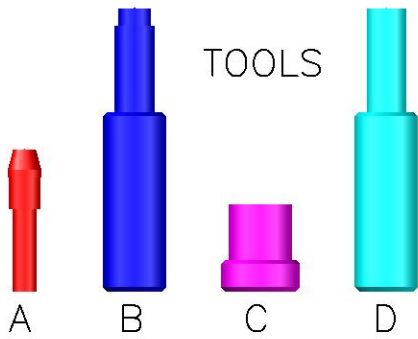

INSTALLATION TOOL SETS CAN BE PURCHASED USING THE FOLLOWING PART NUMBERS:

- PKT-0 FOR VALVE SIZES 1/8"(-0) & 1/4"(-1).
- PKT-2 FOR VALVE SIZE 3/8"(-2).
- PKT-3 FOR VALVE SIZES 1/2"(-3) & 3/4"(-4).
- PKT-5 FOR VALVE SIZE 1"(-5).
- PKT-6 FOR VALVE SIZE 1 1/4"(-6).
- PKT-7 FOR VALVE SIZES 1 1/2"(-7) & 2"(-8).

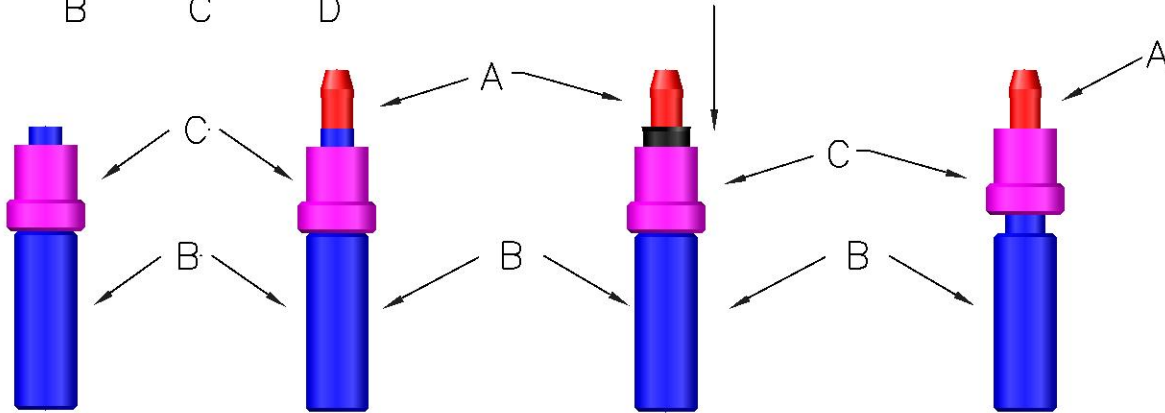

(1) PLACE TOOL B ON FLAT SURFACE. SLIP TOOL C ON TOOL B AS SHOWN.

(2) PLACE TOOL A IN TOOL B AS SHOWN.

(3) PLACE U-CUP PACKING ON TO TOOL A WITH U-CUP FLANGE IN UPWARD POSITION.

(4) PUSH, BY HAND, U-CUP COMPLETELY INTO CAVITY OF TOOL C.

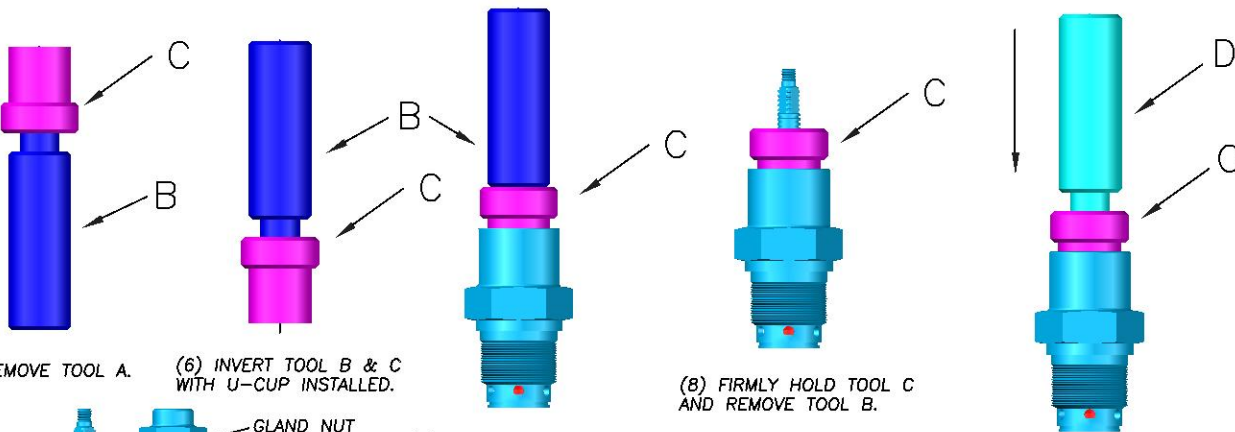

(5) REMOVE TOOL A.

(6) INVERT TOOL B & C WITH U-CUP INSTALLED.

(8) FIRMLY HOLD TOOL C AND REMOVE TOOL B.

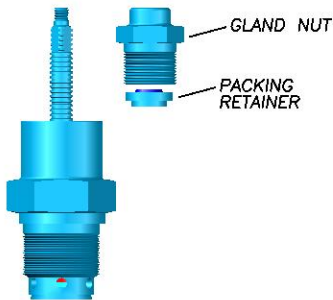

(7) WITH CARTRIDGE IN VERTICAL POSITION, PLACE TOOL B & C OVER STEM AND INTO BONNET UNTIL IT BOTTOMS OUT.

(9) PLACE TOOL D OVER STEM AND FIRMLY PUSH DOWN UNTIL YOU FEEL THAT THE U-CUP HAS SEATED IN THE GLAND.

(10) REMOVE TOOL C & D AND INSTALL PACKING RETAINER AND GLAND NUT, FOLLOWING VALVE ASSEMBLY INSTRUCTIONS.

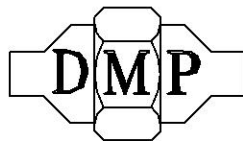

"GET THE CONNECTION"
DERBYSHIRE MARINE PRODUCTS, LLC.

HARLEYSVILLE, PA 19438

TEL: 267-222-8900, FAX: 267-222-8865

Web: www.derbyshiremp.com